

# 120kW Smart Photovoltaic Outdoor Cabinet for Highways



## 120kW Smart Photovoltaic Outdoor Cabinet for Highways

---



### Outdoor Photovoltaic Energy Cabinet

It is built specifically for outdoor installation and integrates advanced LiFePO4 battery technology, a high-level battery management system, and secure weatherproof housing, making it ideal for ...

### One Site One Cabinet Power Cabinet Solution

Huawei's One Site One Cabinet power cabinet solution uses a compact, high-density design to simplify site management, reduce energy use, and support sustainable operations.

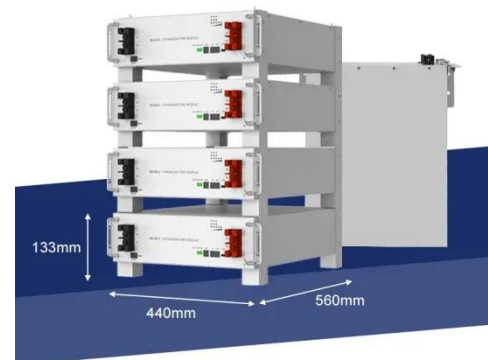

### 215kWh + 120kW High Voltage Integrated Energy Storage Cabinet

Featuring 215kWh of LiFePO4 storage and a 120kW PCS, this system is engineered for industrial parks and commercial complexes that require high-power energy management.

## 120KWH commercial energy storage system\_Lithium Battery Storage ...

Peak shaving and valley filling: by charging and storing energy at valley time and discharging energy at peak time, the electricity cost of customers can be reduced and the electricity charge at the power ...



## Advanced Outdoor Energy Cabinet with Built-in Safety , 50kW / ...

This isn't just a battery; it's a fully integrated power fortress, combining a massive 120kWh LiFePO4 battery bank, a powerful 50kW inverter, and a sophisticated thermal management system within a ...

## LFP Battery Pack , Solar Storage Solution

The 120 kW automatic switching cabinet integrates STS-based control, protection, and monitoring functions to enable safe and automatic grid-connected and off-grid operation works with energy ...



## Outdoor Cabinet Energy Storage System



Product Features: Standardized structure design, menu-type function configuration, photovoltaic charging module, a parallel off-grid switching module, power frequency transformer, and other ...

## Integrated Energy Storage Cabinet

The design of Sandpoint outdoor integrated cabinet energy storage system has independent self-power supply system, temperature control system, fire detection system, fire protection system, emergency ...

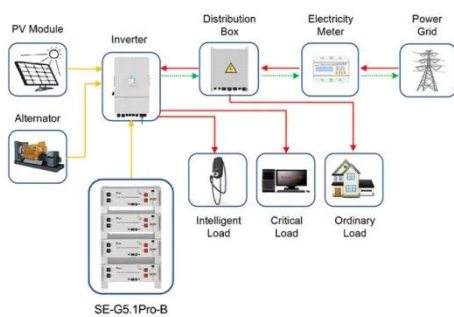

Application scenarios of energy storage battery products

## HENTG POWER 120kW All-in-One Solar Inverter Boost Energy ...

Integrated Design: Combines inverter, transformer, and high-voltage units in one compact unit, saving space and installation time. High-Efficiency Inverter: >98.5% conversion efficiency minimizes power ...

## Outdoor Photovoltaic Energy Cabinet, Base Station Energy

## Storage

Highjoule's Outdoor Photovoltaic Energy Cabinet and Base Station Energy Storage systems deliver reliable, weather-resistant solar power for telecom, remote sites, and microgrids.



---

## Contact Us

For catalog requests, pricing, or partnerships, please visit:  
<https://www.kidsandparents.pl>

