

Price quote for 100kW energy storage cabinet for mining in southeast asia



Overview

The cost of a 100kW battery storage system can vary widely based on the components and features you choose. Here's a breakdown of typical budget ranges: 1. Standard Lithium-Ion System: \$120,000 - \$160,000 Components: Includes standard lithium-ion batteries, basic BMS, and a. For large containerized systems (e., 100 kWh or more), the cost can drop to \$180 - \$300 per kWh. Wondering how much a modern energy storage charging cabinet costs?

This. Wondering how much a modern energy storage charging cabinet costs?

This comprehensive guide breaks down pricing factors, industry benchmarks, and emerging trends for commercial and industrial buyers. Prices swing between \$25,000 and \$70,000 —like comparing a budget sedan to a luxury EV. But why the wild range?

Let's break this down. It supports three operating modes: hybrid, on-grid, and off-grid, allowing you to use it as your backup energy source and a revenue-generating system at any time. Enhance your efficiency, reduce costs, and achieve your sustainability goals with our comprehensive portfolio of integrated energy management solutions. Drive digital transformation.

Price quote for 100kW energy storage cabinet for mining in southeast



Small-scale cost of outdoor energy storage cabinets for Southeast ...

ICEENG CABINET serves customers in 18+ countries across Africa, providing outdoor communication cabinets, power equipment enclosures, and battery energy storage cabinets for telecommunications, ...

New Energy Storage Charging Cabinet Price List: 2024 Cost Guide

GLASHAUS POWER - Wondering how much a modern energy storage charging cabinet costs? This comprehensive guide breaks down pricing factors, industry benchmarks, and emerging trends for ...



100kW-215kWh Liquid-cooled Energy Storage Cabinets

The system consists of one set of 215kwh battery unit, one set of 100kw PCS with liquid cooling system and gas fire protection system, which improves product efficiency and working stability.

100kw 225kwh Photovoltaic Energy Storage Cabinet Bess Solar ...

Our factory operates a 24-hour automated production line specializing in the manufacturing of high-voltage lithium batteries and integrated lithium battery energy storage systems for commercial and ...



Bess Industrial Rack Cabinets Solar Power 100kw Energy Storage ...

The industrial and commercial energy storage cabinets developed by COREY use an integrated design with good flexibility. This design ensures that companies can easily expand their storage capacity to ...

Renepoly 100kW 215kWh Lithium Battery ESS Energy Storage ...

Renepoly 100kW 215kWh Lithium Battery ESS Energy Storage System Liquid Cooled Cabinet with Smart EMS for Industrial Microgrid



How Much Does A 100kw

Battery Storage System Cost

How much does a 50kW energy storage battery cabinet cost for Southeast Asian islands Here's a breakdown of estimated costs: Total Estimated Cost: \$245,000 - \$315,000 Reference: ...



Energy Storage Cabinet 100kW Price: What You Need to Know in 2024

Let's face it--if you're reading this, you're probably either an engineer, a facility manager, or a renewable energy enthusiast trying to decode the mystery behind energy storage cabinet 100kW price tags.



100KW Lithium Ion Battery Storage Cabinets

For a free quote on our wide variety of designs, just provide your email or phone number in the contact form--we'll get it to you promptly.

Commercial and Industrial Energy Storage Cabinet BESS , Anern

Anern liquid cooling energy storage system cabinet is an energy storage device based on 100kw lithium battery. C& I energy storage system. High energy density, high charging and discharging power, long ...

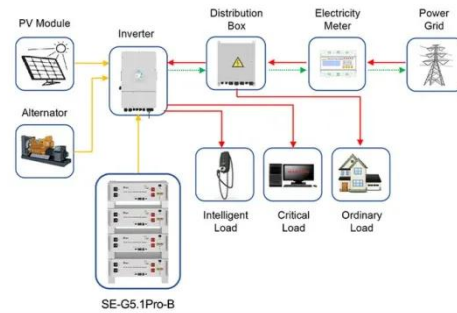

Application scenarios of energy storage battery products

Contact Us

For catalog requests, pricing, or partnerships, please visit:
<https://www.kidsandparents.pl>

